

# -86°C SUPER FREEZER SOFCSF-485

## INTERNAL FEATURES

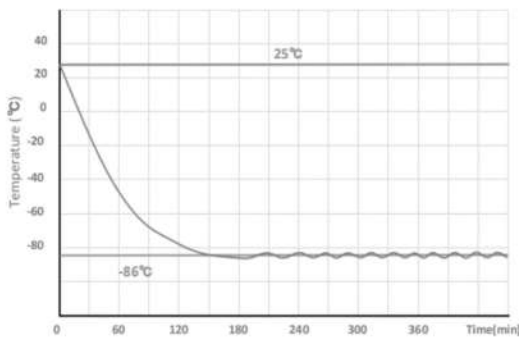

## TYPICAL PERFORMANCE CHARACTERISTICS IN 25°C AMBIENT



Pull down times.

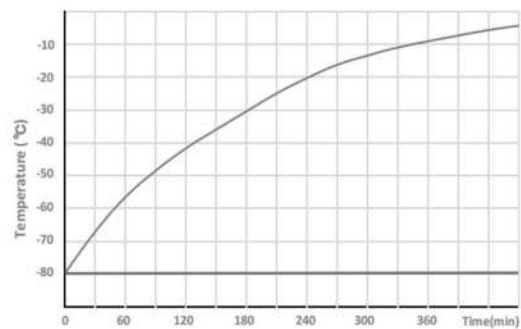

Warm up times.

# SPECIFICATIONS

BASIC	
Cooling Method	Direct Cooling
Defrost	Manual
Temperature Range (°C)	-40~-86
Ambient temperature (°C)	10~32
Display	LED Digital
Access port QTY/ Diameter	1 / 25MM
USB Interface	N/A
Remote Alarm Access	N/A
Outside Material	Color sprayed steel
Inside Material	304 Stainless Steel
Castor Wheels	Included
Power Failure Backup	N/A
REFRIGERATION SYSTEM	
Refrigerant	R4001 (mixed gas)
Temperature Controller	Microprocessor
Cooling System	Auto-cascade
Sensor	PTC 100
Pull down time *(min)	307
Warm up time * (min)	220
Compressor brand/ QTY	SECOP / 1
Capacity (L/cu.ft)	485 / 17.12
Insulation	Polyurethane Rigid Foam
Racks	24(11x1) + 6(6X1)
Boxes (2inches)	300
Sample (2ml)	30000
ELECTRICAL DATA	
Voltage/ Frequency (V/Hz)	220V / 50Hz or 60Hz
Power (W)	670
Current (A)	3.16A
Power Consumption (kWh/24h)	13.5
Noise (db)	50
DIMENSIONS	
Package Size (WxDxH) mm	1765 x 900 x 1060
Exterior Size (WxDxH) mm	1695 x 840 x 962
Interior Size (WxDxH) mm	1455.5 x 525.2 x 674
Shipping CBM	1.68
NW./GW/ (kg)	130/150
20GP/40GP/40HQ	6/13/13
ACCESSORIES	
Data Logger	Optional
ALARMS	
High / Low Temperature	
Sensor Error	
Thermostat Failure	

Sofia Ref. LLC



Sales@sofiaref.com

# SHOP DRAWINGS

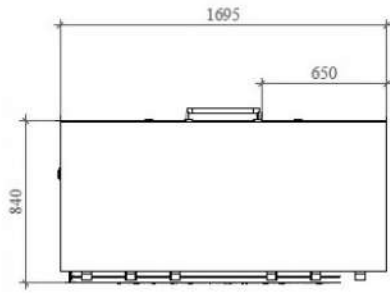

2 PLAN VIEW

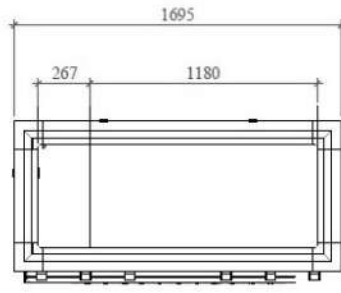

SECTIONAL PLAN VIEW

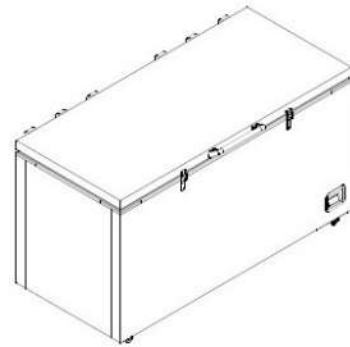

1 ISOMETRIC VIEW

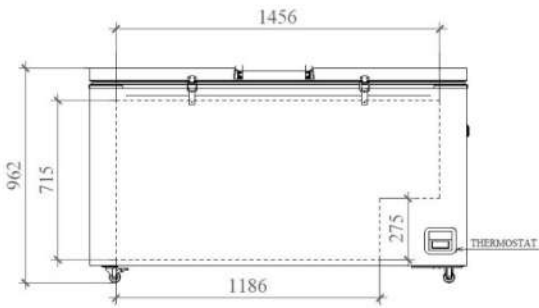

3 FRONT VIEW

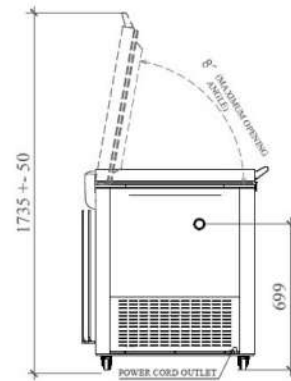

4 SIDE VIEW

## AUTO-CASCADE SYSTEM EXCHANGE CIRCULATION

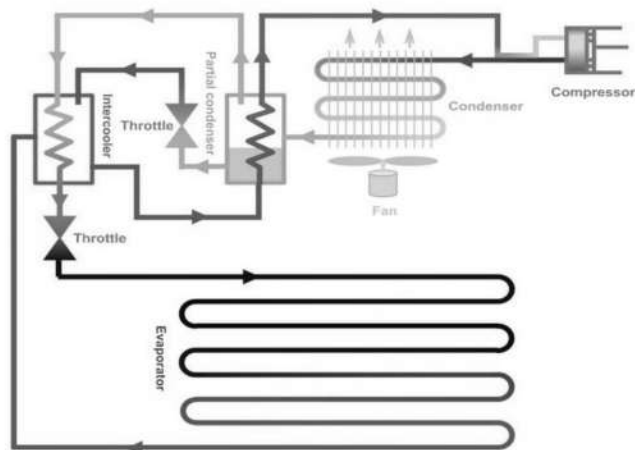

Sofia Ref. LLC



Sales@sofiaref.com