

# BLAST CHILLER-FREEZER-10 TRAYS

## SOFBCF-10



### Details

- Grade 304 stainless steel interior and exterior
- Forced air cooling system
- 85 mm insulation thickness
- CFC free refrigerant R404A
- EVCO digital controller
- Built-in shelf brackets
- Auto defrosting system
- Professional blast freezer thermostat, with HACCP functions
- Stainless steel tray brackets for 1/1 GN pan or 60x40 cm baking trays
- Removable door gasket
- Blast Chilling: Max 1.5 hours from +90°C to +3°C
- Blast Freezing: Max 4.0 hours from +90°C to -18°C

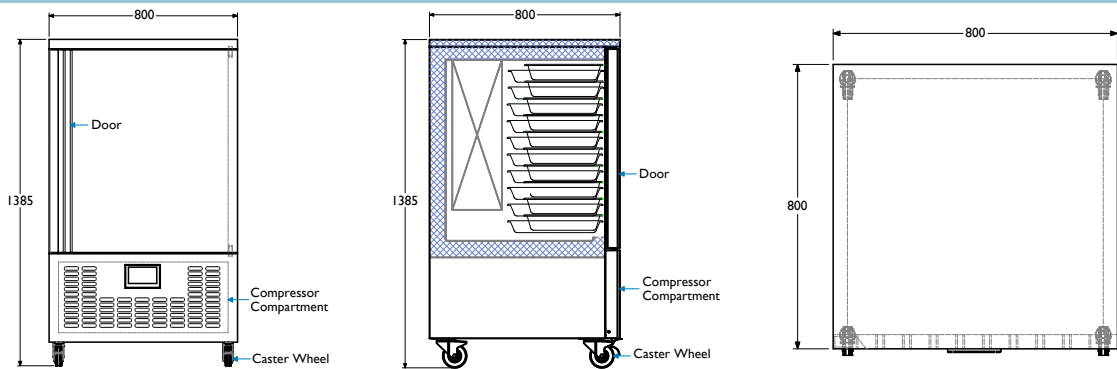

### Specifications

Model	Exterior Dimensions WxDxH (mm)	Capacity in Litres	Power (W)	Voltage Supply	Frequency (Hz)	Temperature Range (°C)	Enviromental Temperature (°C)	Mode of Refrigeration
SOFBCF-10	800x800x1385	209L /10 trays	960	220~240V - 1PH	50 or 60	-40~+3	3 2	Ventilated

Sofia Ref. LLC



Sales@sofiaref.com