

LOW BOY TWO DRAWER FREEZER

SOFL-120 FE



Details

- Grade 304 stainless steel interior and exterior
- Digital temperature control and display
- Radius internal corners for easy cleaning
- Removable track support for easy cleaning
- Adjustable stainless-steel legs; Total height range: 650mm -675mm
- Fits 2 x 1/1 GN containers in each drawer (GN excluded)

Options

- Include Caster wheels

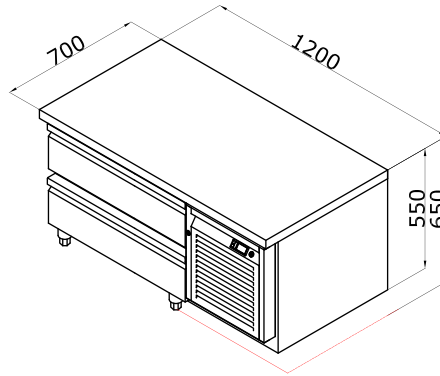

Specifications

Model	Exterior Dimensions WxDxH (mm)	Capacity in Litres	Power (W)	Voltage Supply	Frequency (Hz)	Temperature Range (°C)	Environmental Temperature (°C)	Mode of Refrigeration
SOFL-120 FE	1200x700x650	155	495	220~240V I PH	50 or 60	-18~-20	43	Ventilated

Sofia Ref. LLC

Sheikh Zayed Rd. Dubai, U.A.E - Sajaah Industrial Area Sharjah, U.A.E - Tashkeel Tower Riyadh, K.S.A



Sales@sofiaref.com