

# DOUBLE DOOR UPRIGHT FREEZER

## SOFUP-1275 FE

### Details

- Grade 304 stainless steel interior and exterior
- Digital temperature control and display
- Radius internal corners for easy cleaning
- Removable door gasket
- Lockable doors
- Heavy duty brake and swivel caster wheels
- 6 PVC coated grid shelves included
- 6 shelf brackets included
- Fits 2 x 1/1 GN containers on each shelf (GN excluded)



### Options

- Additional shelves and shelf brackets
- Glass door

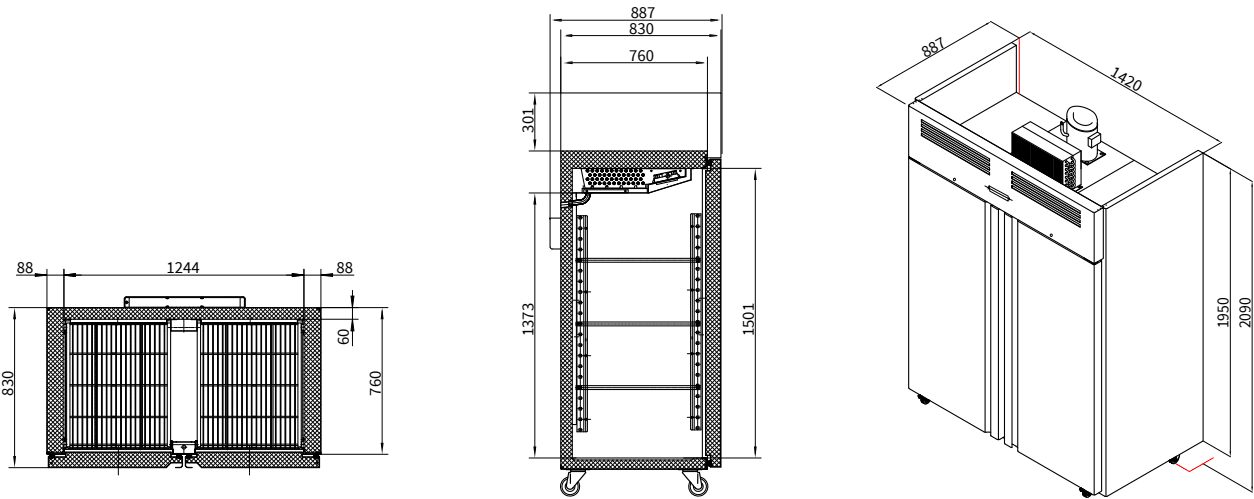

### Specifications

Model	Exterior Dimensions WxDxH (mm)	Capacity in Litres	Power (W)	Voltage Supply	Frequency (Hz)	Temperature Range (°C)	Environmental Temperature (°C)	Refrigerant	Mode of Refrigeration
SOFUP-1275 FE	1420x887x2090	1270	650	220~240V   1PH	50	-18~-22	43	R290	Built-in

Sofia Ref. LLC



Sales@sofiaref.com